

PAD PRINTING SYSTEM FOR PROMOTIONAL GIFTS



MACHINE:	4 TPE 150
PERIPHERAL:	Rotary table
PRINTED PART:	Promotional gifts
PRINT:	4 colours
DRIVE:	pneumatically / electromechanical
ELECTRICAL	
CONNECTION:	3 x 400 / 230 V, 50 Hz
AIR PRESSURE:	min. 6 bar
AIR CONSUMPTION:	approx. 3,4 m ³ / h
SYSTEM DIMENSIONS	
L x W x H:	2700 x 1800 x 1600 mm
WEIGHT:	approx. 950 kg
CONTROL:	Omron SPS
CAPACITY:	1000 pieces / h
LAYOUT:	see reverse side

DESCRIPTION OF SYSTEM

The parts to be printed will be manually loaded to the tooling fixture by the operator. The part will index around a rotary table and subsequently to four single color pad printing machines, stationed around the rotary table. After the fourth colour is transferred, the part will continue to index around to the operator, whereby it will be unloaded manually. During this operation, two of the four machines can be taken off line, turned 180°, and used as manual, one-color printing stations.



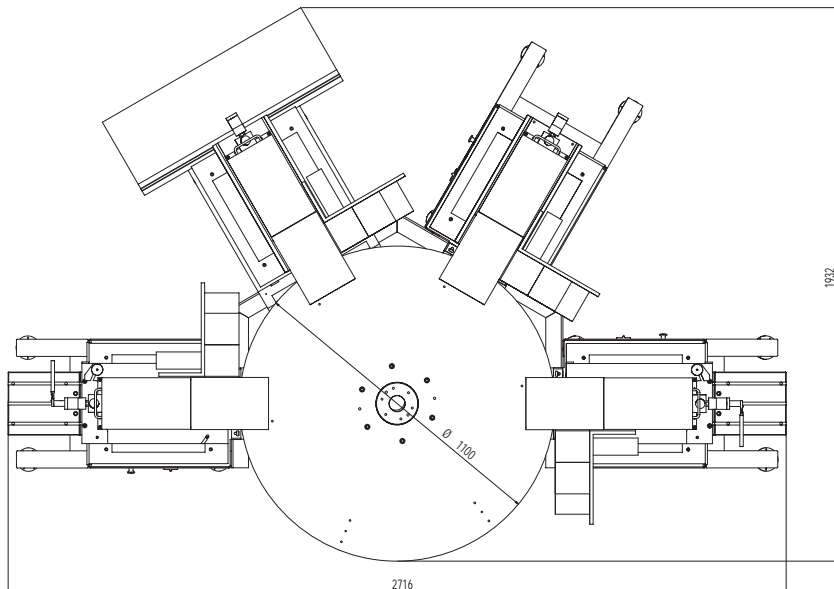
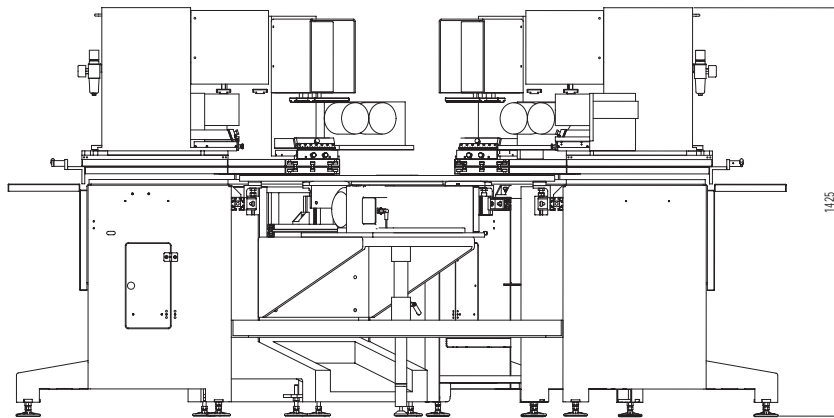
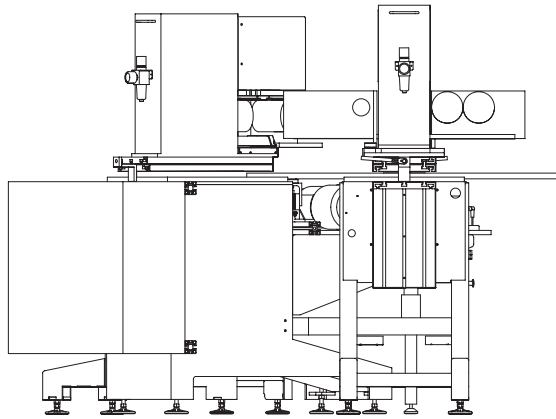

Pad printing system for promotional gifts

706 000 255 / 02.06



Teca-Print AG

Postfach
Bohlstrasse 17
CH-8240 Thayngen

Tel. +41 (0)52 645 2000

Tel. +41 (0)52 FON TECA

Fax +41 (0)52 645 2101

info@teca-print.ch

teca-print.com